



S E R V E R

SERVE BETTER™

## INSULATED RELISH SERVER

**IRS-3**  
**3 PAN**  
Series 07A  
**67080**

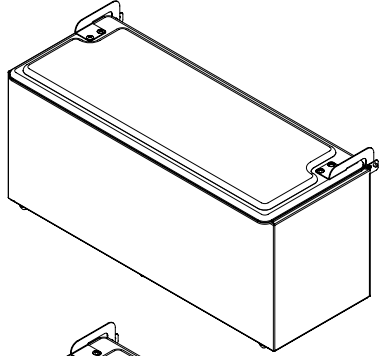

**IRS-3DI**  
**3 PAN, DROP-IN**  
Series 07A  
**67160**

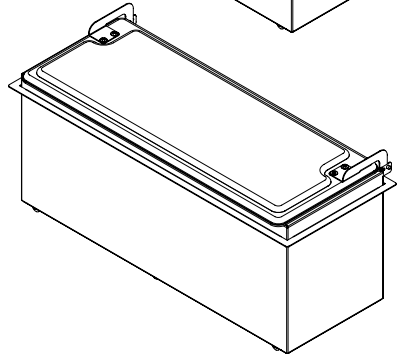

**IRS-2**  
**2 PAN**  
Series 07A  
**67770**

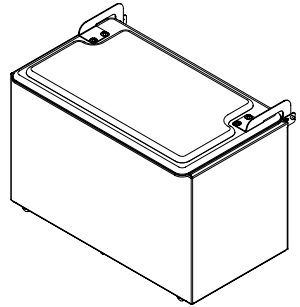

**IRS-2DI**  
**2 PAN, DROP-IN**  
Series 07A  
**67780**

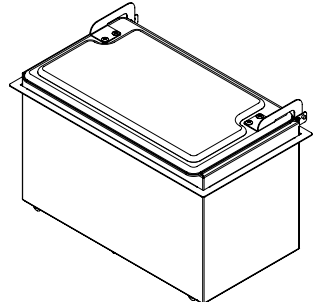

# SAFETY GUIDELINES WHEN USING THIS UNIT:

According to food and safety regulations, most foods must be stored and/or served at certain temperatures or they could become hazardous. Check with local food and safety regulators for specific guidelines.

**Be aware of the product you are serving and the temperature the product is required to maintain. Server Products, Inc. can not be responsible for the serving of potentially hazardous product.**

Stainless steel is one of the best materials for food serving and storage, but there are many products which can corrode it. If you notice corrosion beginning on any stainless steel surface, you may need to change the cleansing agent, sanitizing agent, or the cleaning procedures you are using.

- Products containing: acids, alkalines, chlorine, or salt can corrode stainless steel.
- Sauerkraut and Au Jus sauces corrode stainless steel. Server Products, Inc. regrets that we can not honor Warranty claims on stainless steel parts that have been affected by sauerkraut or Aus Jus.

## Insulated Units

- Do not place ice packs or crushed ice into non-insulated units, they are not designed to hold water and will leak.
- Do not expose insulated shroud or base of unit to a dishwasher or temperatures over 150°F, this will damage the insulation.

## Eutectic Ice Packs

- Do not expose ice packs to a dishwasher or any extreme heat, this could cause leakage or explosion of the ice packs. The operating temperature range for the eutectic ice packs is between -40°F and 175°F.

# SPECIFIC INFORMATION

Various 1/6 optional pans available:		
Stainless Steel Pans	90087	2.5" deep
	90088	4" deep
	90089	6" deep
Plastic Pans	90116	2.5" deep
	90179	4" deep
	90177	6" deep

# DROP-IN UNITS

Drop-In units can be used either on a counter top surface or can be dropped into an opening in a counter top.

MODEL Number	Recommended Counter Top Opening Size
67780	13 3/4" x 7 3/8" = 13.75" x 7.375"

# UNIT SET-UP

ALWAYS CLEAN UNIT THOROUGHLY BEFORE EACH USE. SEE UNIT TAKE-DOWN, SAFETY GUIDELINES AND CLEANING.

**Server Products Inc. claims no responsibility for actual serving temperature of product. It is the responsibility of the user to ensure that any product is held and served at a safe temperature.**

- 1 FOR INSULATED UNITS ONLY, INSTALL ICE PACKS INTO BOTTOM OF UNIT.
  - Optional ice packs available: Eutectic #94013 Round.
  - Optional round eutectic ice packs are refreezable, allow them to freeze for about 12 hours (or overnight) before each UNIT SET-UP.
  - Each ice pack will maintain a temperature of 45°F or below for about 4 hours.
  - If you do not have ice packs, fill insulated unit with crushed ice up to level where bottom of pans will just touch ice.
- 2 INSTALL PANS INTO UNIT.
- 3 LID HINGE CAN BE INSTALLED TWO WAYS:
  - Attach to inside hinge pins for self-closing lid.
  - Attach to outside hinge pins for non-self-closing.
  - Install lid onto unit by pulling or pushing each hinge on lid to allow pins on unit to engage into holes in hinges.
- 4 CLOSE LID.

# UNIT TAKE-DOWN

- 1 REMOVE LID FOR CLEANING BY PUSHING HINGES, ON LID, TO DISENGAGE PINS ON UNIT FROM HOLES IN HINGES.
- 2 REMOVE PANS FROM UNIT.
- 3 FOR INSULATED UNITS ONLY, REMOVE ICE PACKS FROM BOTTOM OF UNIT.
  - Optional round eutectic ice packs are refreezable, allow them to freeze for about 12 hours (or overnight) before each UNIT SET-UP.
  - If you do not have ice packs, and insulated unit was filled with crushed ice, tip unit over a drain to empty out all remaining ice or water.

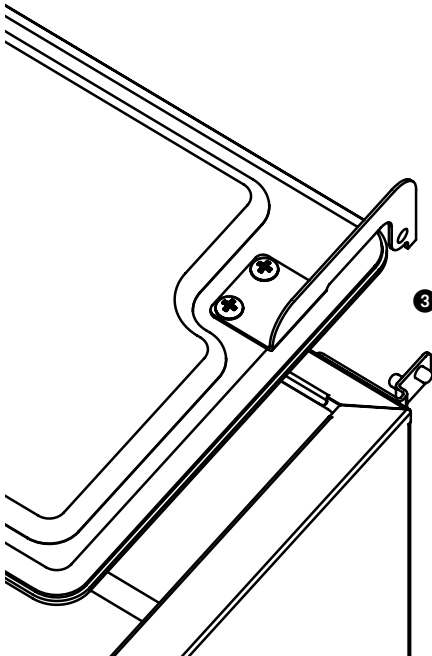
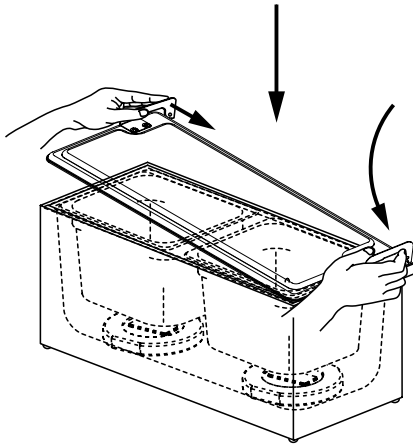
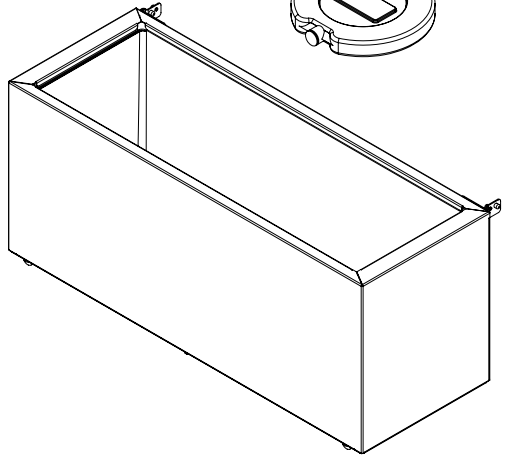
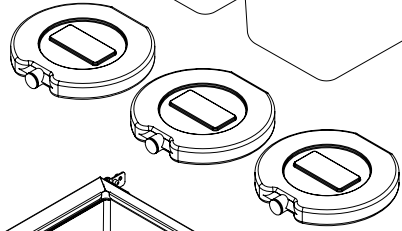
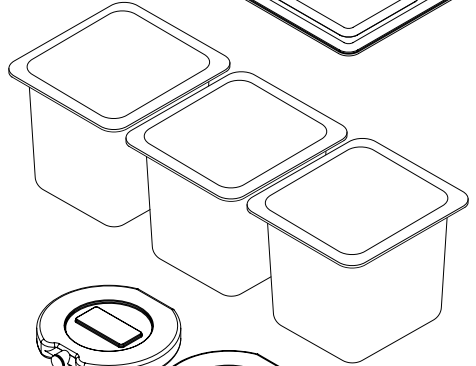
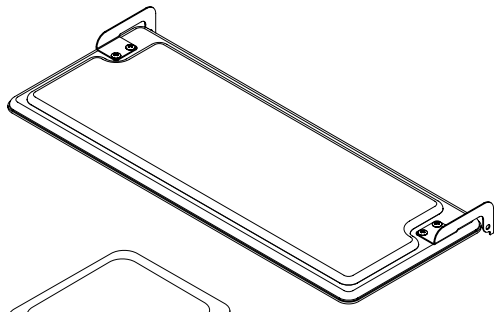

**3** LID HINGE CAN BE INSTALLED TWO WAYS:

- Attach to inside hinge pins for self-closing lid.
- Attach to outside hinge pins for non-self-closing.
- Install lid onto unit by pulling or pushing each hinge on lid to allow pins on unit to engage into holes in hinges.

## UNIT CLEANING

BEFORE FIRST USE AND AFTER USE DAILY OR REGULARLY, DISASSEMBLE AND CLEAN PARTS. FOR SAFE AND PROPER CARE, AND TO PREVENT CORROSION, OF PARTS, IT IS IMPORTANT TO CLEAN, RINSE, SANITIZE, AND DRY PARTS DAILY OR REGULARLY. FAILURE TO COMPLY WITH ANY OF THESE INSTRUCTIONS MAY VOID UNIT WARRANTY.

- 1 SEE UNIT TAKE DOWN.
- 2 WASH CLEAN ALL PARTS WITH DISHWASHING DETERGENT AND HOT WATER.
  - Do not use scrapers, steel pads, steel wool, or other cleaning tools that can scratch surfaces.
  - Mildly abrasive NYLON or brass brush may be used to remove any stubborn food or mineral deposits on interior surfaces of unit.
  - Do not use abrasive cleansers.
  - Do not use caustic cleansers.
  - Do not use cleansing agents with high concentrations of acid, alkaline or chlorine.
  - Do not use ammonia based cleansers.
- 3 FULLY RINSE ALL WASHED PARTS THOROUGHLY WITH CLEAR WATER.
  - To prevent corrosion on parts, it is important to thoroughly and fully rinse washed parts.
- 4 WIPE CLEAN EXTERNAL SURFACES OF UNIT WITH A CLEAN DAMP CLOTH.
  - Nontoxic glass cleaner may be used to clean stainless steel parts.
- 5 DRY ALL PARTS WITH A CLEAN SOFT CLOTH.
  - Various elements and minerals, such as chlorides in tap water, can accumulate on stainless steel parts and create corrosion.
  - To prevent corrosion on stainless steel parts, it is important to thoroughly and fully dry with a clean soft cloth regularly.
- 6 SANITIZE ALL PARTS FOLLOWING LOCAL SANITIZATION REQUIREMENTS. ALL PARTS IN CONTACT WITH FOOD MUST BE SANITIZED.
  - Allow parts to fully air dry after sanitization.

## GENERAL SERVICE, REPAIR, OR RETURNS

Before sending any item to Server Products for service, repair, or return, contact Server Products customer service to request a **Return Authorization Number**. Merchandise must be sent to Server Products with this number.

Merchandise being returned for credit must be in new and unused condition and not more than 90 days old and will be subject to a 20% (percent) restocking charge. Electrical parts (thermostats, heating elements, etc.) are not returnable.

Server Products maintains a fully staffed service department with highly skilled factory trained personnel. Service is extremely prompt. Under normal circumstances, a repaired unit is shipped out the day after it is received. Labor charges are reasonable.

## SERVICE

Contact your dealer or Server Products Inc. customer service department for the following:

### ORDERING REPLACEMENT PARTS

#### Be prepared to give this information:

- Model Letters/Name/Numbers
- Part Numbers- P/N
- Series Numbers/Letters
- Part Description

This information and other important data is stamped on the lid or cylinder of pumps or on the bottom or back side of every unit.

## SERVER PRODUCTS LIMITED WARRANTY

All Server Products equipment is backed by a two-year limited warranty against defects in materials and workmanship. For complete warranty information go to: [www.server-products.com](http://www.server-products.com)



**Server Products Inc.**

3601 Pleasant Hill Road  
Richfield, WI 53076 USA



262.628.5600



800.558.8722



262.628.5110



[spsales@server-products.com](mailto:spsales@server-products.com)



[www.server-products.com](http://www.server-products.com)